

FSN Series Installation: System Connections

For detailed installation instructions, refer to **Chapter 4** of the User's Guide.

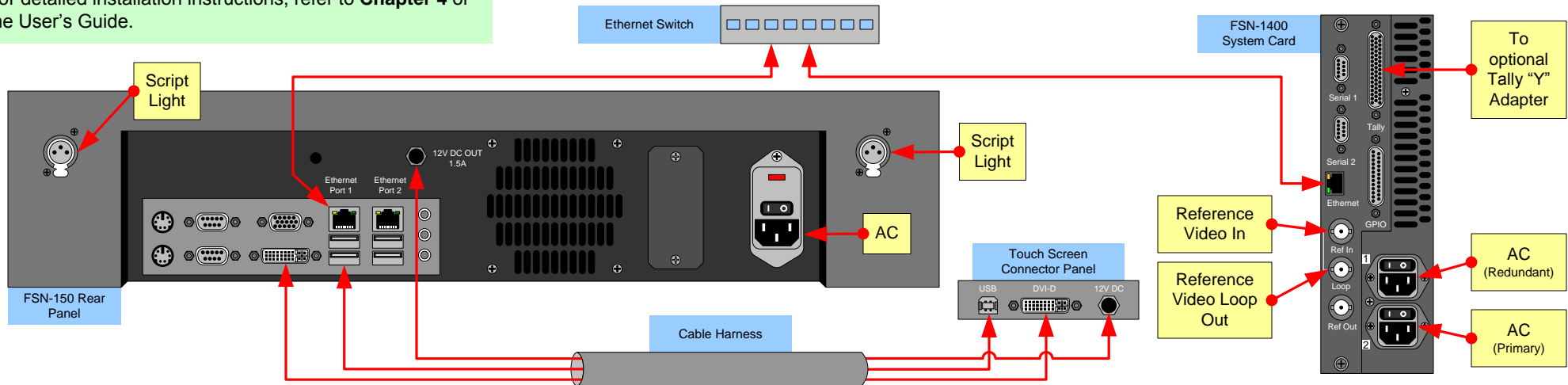

System Setup



System setup is comprised of 18 sequences, each of which includes many steps.

For error-free setup, always refer to the associated section in **Chapter 6** of the User's Guide.

The circled sequence numbers are identical.

- 1 **Power Up and Status Check** — Power up the FSN-1400, control panel, all monitors and peripherals. In the **System Menu** tables, ensure that all devices are connected, and all cards are recognized.
- 2 **Return to Factory Default** — For a new event, back up your system if desired, then on the **Reset Menu**, perform a complete factory reset. For a continuing (or multi-day) event, this step is not required.
- 3 **Touch Screen Calibration** — (Optional) On the **Diagnostics Menu**, calibrate the Touch Screen. If calibration is off, simultaneously press **FINE ADJUST** and **ENTER** on the Keypad to start the procedure.
- 4 **Communications Setup** — On the **Communications Setup Menu**, check the table to ensure that all devices are connected. If not, press **{Discover FSN-1400}** and connect to the desired frame, or re-check connections.

- 5 **Restoring the System** — (Optional) Insert a USB drive with a previous backup file into the **USB Port**. On the **Backup and Restore Menu**, press **{Restore System}** and follow the prompts. No further setup operations are required.
- 6 **Reference and Output Setup** — On the **Reference and Output Setup Menu**, select the desired video reference input, output video format and output V-lock mode.
- 7 **Output Test Patterns** — (Optional) On the **Output Test Patterns Menu**, select and display test patterns on one or more outputs, to assist with external device setup. Press **{All Off}** when you are finished.
- 8 **Clean Feed Setup** — On the **Clean Feed Setup Menu**, select the clean feeds for the M/E 1, M/E 2 and PGM clean outputs. Press **{Assign Button}** and select the desired point for the **ASSIGN** button (in the Aux section).
- 9 **Native Input Setup** — On the **Input Menu**, select a NIC input, then map and name it. Press **{Setup}**. Set up color correction, sync, and mask (if required). When complete, save settings, and repeat for all NIC inputs.
- 10 **Universal Input Setup** — On the **Input Menu**, select a UIC input, then map and name it. Press **{Setup}**. Set up all parameters on the three setup tabs. When complete, save settings, and repeat for all UIC inputs.
- 11 **External DSK Setup** — (Optional) On the **External DSK Setup Menu**, select the **DSK Fill BNC**, and set color correction parameters if desired. Save the settings. The **DSK Cut** input can not be adjusted.

- 12 **Button Mapping** — On the **Map Buttons Menu**, map inputs, test patterns and color backgrounds to the panel. If required, map linear key cut and fill signals. Use **{SHIFT}** to access shifted buttons.
- 13 **Aux Setup** — (Optional) On the **Aux Setup Menu**, set up all standard and optional Aux outputs, including all installed NACs and UOCs. You can map and name Aux outputs, and set the output resolution for all UOC outputs.
- 14 **Multiviewer Setup** — (Optional) Ensure that the optional Multiviewer is installed in slot 11. On the **Multiviewer Setup Menu**, select the output format and layout, assign sources to PIPs, select all colors and UMD (Under Monitor Display) text.
- 15 **Tally Setup** — (Optional) On the **Tally Setup Menu**, select a tally (1-24), then press **{Select Input}** to assign an input. Select a reference color, switcher outputs, and set tally closures. Repeat for all desired inputs.
- 16 **User Preference Setup** — (Optional) On the **User Preferences Menu**, set the desired preferences for the bus and transition displays, the touch screen and the control panel.
- 17 **Saving the Setup** — On the **System Menu**, press **{Save All}** to save all system parameters to non-volatile memory, including input and output setups, button mappings, tallies, user preferences and more.
- 18 **Backing up the System** — Insert a USB drive into the **USB Port**. On the **Backup and Restore Menu**, press **{Backup System}** to back up the system setup and all memory registers.

FSN Series Installation: I/O Connections

System Connections

System Card I/O Panel

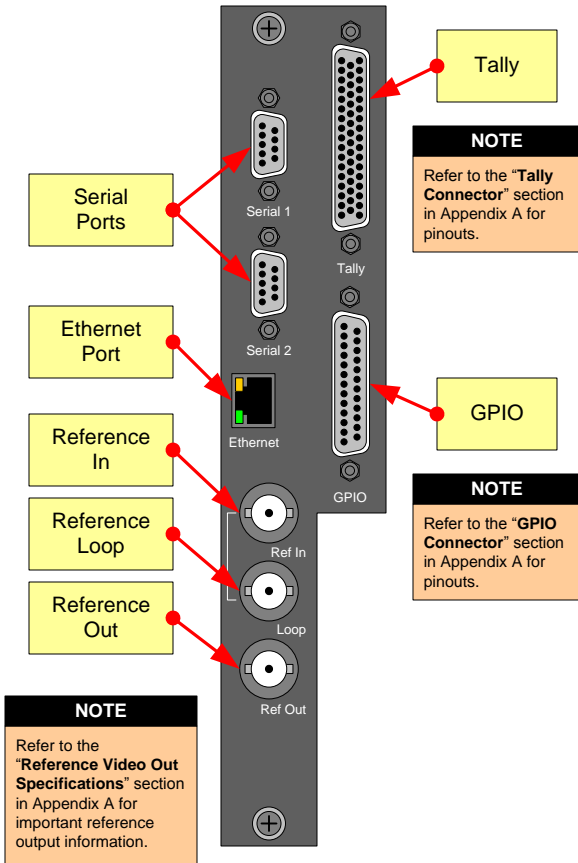

Card Information		
Card Type	Max. # Cards Per Chassis	Slot Number(s)
System	1 (Required)	14

IMPORTANT This card is pre-installed in the frame. Do not move.

Output Connections

M/E Card (Mix Effects) I/O Panel

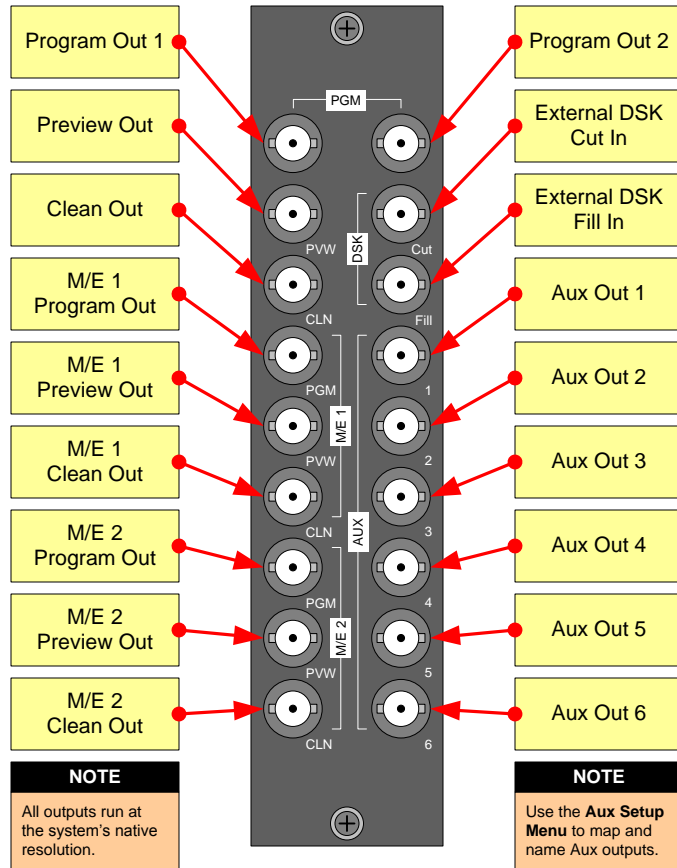

Card Information		
Card Type	Max. # Cards Per Chassis	Slot Number(s)
M/E	1 (Required)	8

IMPORTANT This card is pre-installed in the frame. Do not move.

Native Input Connections

NIC (Native Input Card) I/O Panel

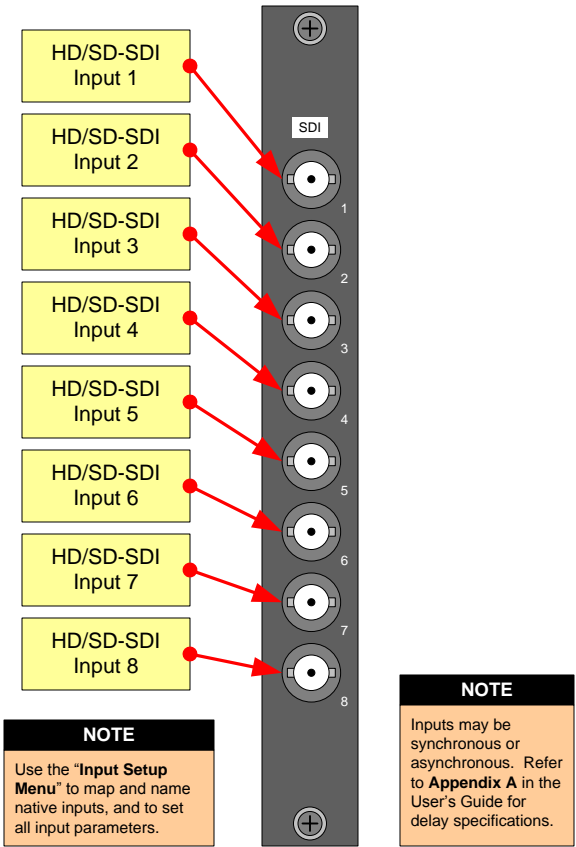

Card Information		
Card Type	Max. # Cards Per Chassis	Slot Number(s)
NIC	4	1 - 4

Default slot: 1

Universal Input Connections

UIC
(Universal Input Card)
I/O Panel

NOTE
Use the "Analog Format Connection Table" on page 4 for input combinations.

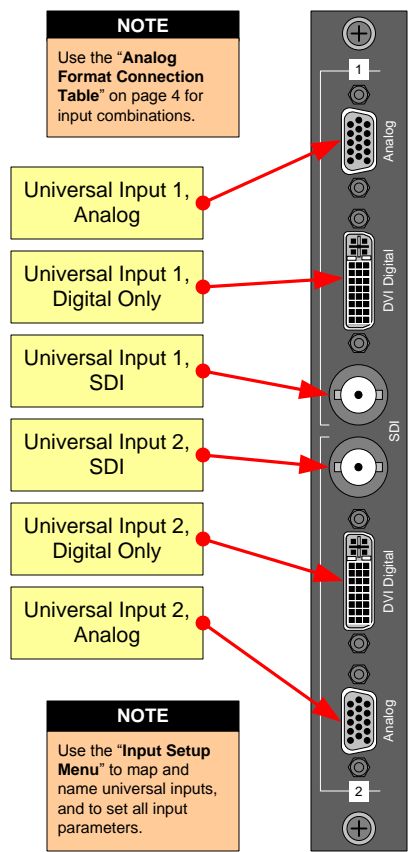

NOTE
Use the "Input Setup Menu" to map and name universal inputs, and to set all input parameters.

Card Information		
Card Type	Max. # Cards Per Chassis	Slot Number(s)
UIC	5	3 - 7
Default slot: 7		

Universal Output Connections

UOC
(Universal Output Card)
I/O Panel

NOTE
Use the "Analog Format Connection Table" on page 4 for output combinations.

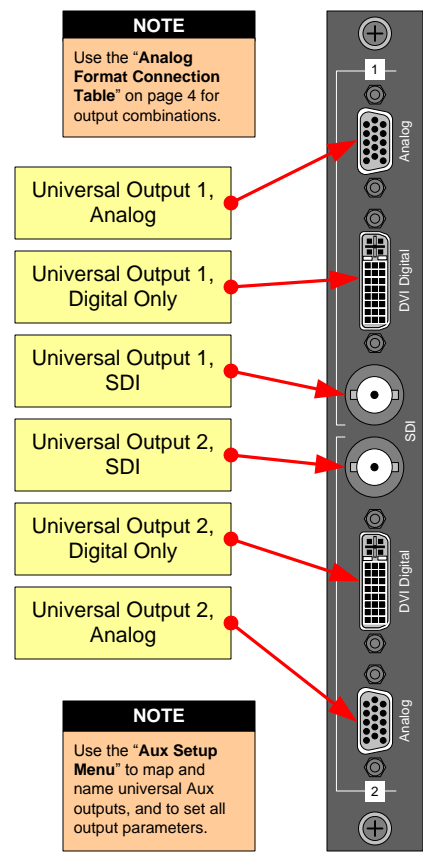

NOTE
Use the "Aux Setup Menu" to map and name universal Aux outputs, and to set all output parameters.

Card Information		
Card Type	Max. # Cards Per Chassis	Slot Number(s)
UOC	3	11, 12, 13
Default slot: 12		

Native Output Connections

NAC
(Native Aux Output Card)
I/O Panel

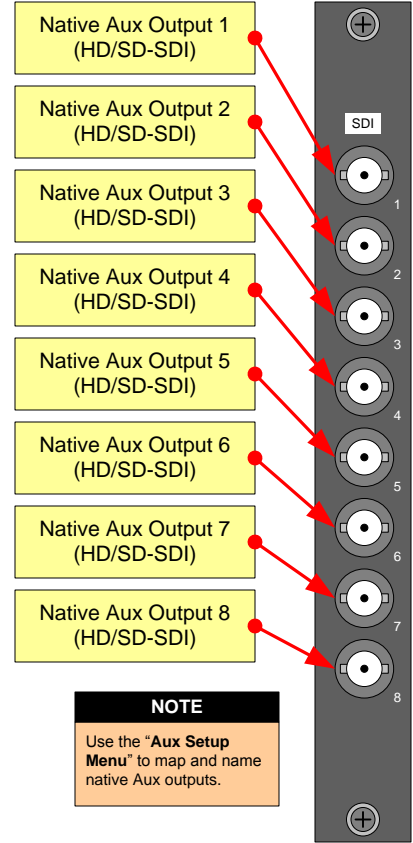

NOTE
Use the "Aux Setup Menu" to map and name native Aux outputs.

NOTE
All outputs run at the system's native resolution.

Card Information		
Card Type	Max. # Cards Per Chassis	Slot Number(s)
NAC	3	11, 12, 13
Default slot: 13		

I/O Connections (continued)

Multiviewer Connections

MVR
(Multiviewer Card)
I/O Panel

MVR (Multiviewer)
Output 1

MVR (Multiviewer)
Output 2

LTC Input

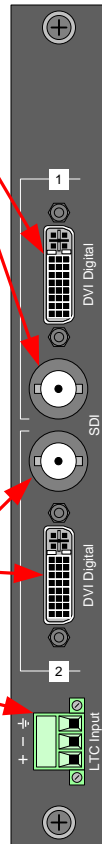

NOTE

For MVR outputs 1 and 2 (regardless of the selected layout), the same output signal appears on both the DVI-I and BNC connectors.

- In single monitor layouts, the selected layout appears identically on MVR outputs 1 and 2.
- In dual monitor layouts, one half of the selected layout appears on MVR Output 1, and the other half appears on MVR Output 2.

DVI-I outputs are always active. BNC outputs are only active for SMPTE video output formats.

Time Code Connections

Differential: use the +, - and GND terminals.
Single-ended: use the + and GND terminals.

Card Information

Card Type	Max. # Cards Per Chassis	Slot Number(s)
MVR	1	11

NOTE

Use the "Multiviewer Setup Menu" to set all multiviewer parameters.

LEDs

Card LEDs

Card Power LED

- Power is OK
- Power is bad or failed on the card
- Chassis is off, or power has failed

Loaded LED

- All FPGAs loaded successfully
- An FPGA is bad, or software not properly loaded
- Chassis is off, or power has failed

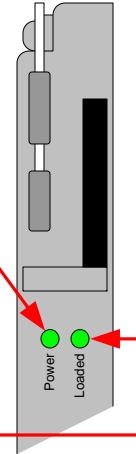

Front Door LEDs

Power LED

- System card has power, and the card's software is running
- Not currently used
- Power is off, or no System card is present, or System card has failed

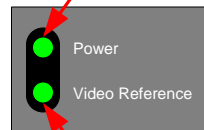

Video Reference LED

- External reference selected, signal is present and FSN-1400 is locked
- External reference selected, signal is missing or FSN-1400 is not locked
- Free Run is selected.

Input / Output Flexibility

Native and Universal Inputs

	Total Inputs (Installed NICs + Installed UICs)					
	0 UIC	1 UIC	2 UIC	3 UIC	4 UIC	5 UIC
0 NIC	0	2	4	6	8	10
1 NIC	8	10	12	14	16	18
2 NICs	16	18	20	22	24	26
3 NICs	24	26	28	30	32	
4 NICs	32	34	36	38		

Native and Universal Aux Outputs

	Total Aux Outputs – Multiviewer Not Installed			
	0 NAC	1 NAC	2 NAC	3 NAC
0 UOC	6	14	22	30
1 UOC	8	16	24	
2 UOC	10	18		
3 UOC	12			

	Multiviewer Installed		
	0 NAC	1 NAC	2 NAC
0 UOC	6	14	22
1 UOC	8	16	
2 UOC	10		

Analog Format Connection Table

Breakout Cable Wire Color	Comp Video	S-Video (Y/C)	YUV (YPbPr)	RGB Sync on Green	RGB Comp Sync	RGB Separate H V
R			✓ (Pr)	✓	✓	✓
G	✓	✓ (Lum)	✓ (Lum)	✓	✓	✓
B		✓ (Chrom)	✓ (Pb)	✓	✓	✓
H Sync					✓	✓
V Sync						✓

FSN Series Notes

- For complete details on the FSN-1400, the control panel, all menus, and all installation, setup, configuration and operations procedures, please refer to the FSN Series User's Guide.
- For the latest version of the Quick Start Guide, visit www.barco.com.
- Any item contained in this document may change without notice.