

# BlendPRO-II



## User's Guide

- Manual # 26-0507000-00
  - Revision A
- 



---

# BlendPRO-II • User's Guide

## Copyright

© Barco, Inc. August 7, 2006

All rights reserved. No part of this document may be copied, reproduced or translated. It shall not otherwise be recorded, transmitted or stored in a retrieval system without the prior written consent of Barco.

## Notice

Barco provides this manual "as is" without warranty of any kind, either expressed or implied, including but not limited to the implied warranties or merchantability and fitness for a particular purpose. Barco may make improvements and/or changes to the product(s) and/or the program(s) described in this publication at any time without notice.

This publication could contain technical inaccuracies or typographical errors. Changes are periodically made to the information in this publication; these changes are incorporated in new editions of this publication.

## Federal Communications Commission (FCC) Statement

This equipment has been tested and found to comply with the limits for a class A digital device, pursuant to Part 15 of the FCC rules. These limits are designed to provide reasonable protection against harmful interference when the equipment is operated in a commercial environment. This equipment generates, uses, and can radiate radio frequency energy and, if not installed and used in accordance with the instruction manual, may cause harmful interference to radio communications. Operation of this equipment in a residential area may cause harmful interference, in which case the user will be responsible for correcting any interference.

## Guarantee and Compensation

Barco provides a guarantee relating to perfect manufacturing as part of the legally stipulated terms of guarantee. On receipt, the purchaser must immediately inspect all delivered goods for damage incurred during transport, as well as for material and manufacturing faults. Barco must be informed immediately in writing of any complaints.

The period of guarantee begins on the date of transfer of risks, in the case of special systems and software on the date of commissioning, at latest 30 days after the transfer of risks. In the event of justified notice of complaint, Barco can repair the fault or provide a replacement at its own discretion within an appropriate period. If this measure proves to be impossible or unsuccessful, the purchaser can demand a reduction in the purchase price or cancellation of the contract. All other claims, in particular those relating to compensation for direct or indirect damage, and also damage attributed to the operation of software as well as to other services provided by Barco, being a component of the system or independent service, will be deemed invalid provided the damage is not proven to be attributed to the absence of properties guaranteed in writing or due to the intent or gross negligence or part of Barco.

If the purchaser or a third party carries out modifications or repairs on goods delivered by Barco, or if the goods are handled incorrectly, in particular if the systems are commissioned operated incorrectly or if, after the transfer of risks, the goods are subject to influences not

agreed upon in the contract, all guarantee claims of the purchaser will be rendered invalid. Not included in the guarantee coverage are system failures which are attributed to programs or special electronic circuitry provided by the purchaser, e.g. interfaces. Normal wear as well as normal maintenance are not subject to the guarantee provided by Barco either.

The environmental conditions as well as the servicing and maintenance regulations specified in this manual must be complied with by the customer.

## Trademarks

Brand and product names mentioned in this manual may be trademarks, registered trademarks or copyrights of their respective holders. All brand and product names mentioned in this manual serve as comments or examples and are not to be understood as advertising for the products or their manufactures.

---

## Company Address



**Barco Media and Entertainment**  
11101 Trade Center Drive  
Rancho Cordova, California 95670  
USA

- Phone: (916) 859-2500
- Fax: (916) 859-2515
- Websites:
  - ~ [www.folsom.com](http://www.folsom.com)
  - ~ [www.events.barco.com](http://www.events.barco.com)

**Barco N.V.**  
Noordlaan 5  
8520 Kurne  
BELGIUM

- Phone: +32 56.36.82.11
- Fax: +32 56.35.16.51
- Website: [www.barco.com](http://www.barco.com)

---

## Operators Safety Summary

The general safety information in this summary is for operating personnel.

### Do Not Remove Covers or Panels

There are no user-serviceable parts within the unit. Removal of the top cover will expose dangerous voltages. To avoid personal injury, do not remove the top cover. Do not operate the unit without the cover installed.

### Power Source

This product is intended to operate from a power source that will not apply more than 230 volts rms between the supply conductors or between both supply conductor and ground. A protective ground connection by way of grounding conductor in the power cord is essential for safe operation.

### Grounding the Product

This product is grounded through the grounding conductor of the power cord. To avoid electrical shock, plug the power cord into a properly wired receptacle before connecting to the product input or output terminals. A protective-ground connection by way of the grounding conductor in the power cord is essential for safe operation.

### Use the Proper Power Cord

Use only the power cord and connector specified for your product. Use only a power cord that is in good condition. Refer cord and connector changes to qualified service personnel.

### Do Not Operate in Explosive Atmospheres

To avoid explosion, do not operate this product in an explosive atmosphere.

---

## Terms In This Manual and Equipment Marking



### WARNING

Highlights an operating procedure, practice, condition, statement, etc., which, if not strictly observed, could result in injury to or death of personnel.

### Note

Highlights an essential operating procedure, condition or statement.



### CAUTION

The exclamation point within an equilateral triangle is intended to alert the user to the presence of important operating and maintenance (servicing) instructions in the literature accompanying the appliance.



### AVERTISSEMENT!

Le point d'exclamation dans un triangle équilatéral signale à alerter l'utilisateur qu'il y a des instructions d'opération et d'entretien très importantes dans la littérature qui accompagne l'appareil.



### VORSICHT

Ein Ausrufungszeichen innerhalb eines gleichwinkligen Dreiecks dient dazu, den Benutzer auf wichtige Bedienungs- und Wartungsanweisungen in der dem Gerät beiliegenden Literatur aufmerksam zu machen.

---

## Change History

The table below lists the changes to the BlendPRO-II User's Guide.

**Table 0-1.** Change History

Rev	Date	ECO #	Description	Approved By
A	8/7/06	1674	BlendPRO-II User's Guide	M. Lettau



# Table of Contents

- Chapter 1 Introduction ..... 9**
  - In This Chapter ..... 9
  - Chapter Structure ..... 10
  - How to Use This Guide ..... 11
    - Navigating ..... 11
    - Table of Contents and Index ..... 11
    - General Operations ..... 11
  - Conventions ..... 11
  - About the BlendPRO-II ..... 12
  - Features ..... 13
  - Application Questions ..... 13
  - Connectivity Diagram ..... 14
  
- Chapter 2 Hardware Orientation ..... 15**
  - In This Chapter ..... 15
  - BlendPRO-II Front Panel ..... 16
  - BlendPRO-II Rear Panel ..... 17
  
- Chapter 3 Installation ..... 21**
  - In This Chapter ..... 21
  - Safety Precautions ..... 22
  - Unpacking and Inspection ..... 22
  - Site Preparation ..... 22
  - Cable and Adapter Information ..... 22
  - Rack-Mount Installation ..... 23
  - Power Installation ..... 23
    - Power Cord/Line Voltage Selection ..... 24
  - Signal Installation ..... 25
    - ScreenPRO-II Genlock Termination ..... 27
  - Format Connection Table ..... 28
  
- Chapter 4 Operation ..... 29**
  - In This Chapter ..... 29
  - Control Overview ..... 30
  
- Chapter 5 Upgrading Software ..... 31**
  - In This Chapter ..... 31
  - Software Upgrade Overview ..... 32

## Table of Contents

<b>Appendix A</b>	<b>Specifications.....</b>	<b>33</b>
	In This Appendix.....	33
	Input Specifications.....	34
	Output Specifications.....	34
	User Control Specifications.....	35
	Physical and Electrical Specifications.....	35
	Communications Specifications.....	36
	Agency Specifications.....	36
	Pinouts.....	37
	Analog 15-pin D Connector.....	37
	DVI Connector Pinouts.....	38
	Ethernet Connector.....	39
	Serial Connector.....	40
<b>Appendix B</b>	<b>Contact Information.....</b>	<b>41</b>
	In This Appendix.....	41
	Warranty.....	41
	Return Material Authorization (RMA).....	41
	Contact Information.....	42
<b>Index</b>	<b>.....</b>	<b>43</b>



# 1. Introduction

---

## In This Chapter

This chapter is designed to introduce you to the BlendPRO-II User's Guide. Areas to be covered are:

- [Chapter Structure](#)
- [How to Use This Guide](#)
- [Conventions](#)
- [About the BlendPRO-II](#)
- [Features](#)
- [Application Questions](#)
- [Connectivity Diagram](#)

# 1. Introduction

## Chapter Structure

---

## Chapter Structure

The following chapters provide instructions for all aspects of BlendPRO-II operations:

- Chapter 1, “[Introduction](#)” provides a system overview, a list of features, and a system connectivity diagram.
- Chapter 2, “[Hardware Orientation](#)” on page 15 provides detailed diagrams of the system’s front and rear panels.
- Chapter 3, “[Installation](#)” on page 21 provides comprehensive system installation instructions.
- Chapter 4, “[Operation](#)” on page 29 provides system operating instructions.
- Chapter 5, “[Upgrading Software](#)” on page 31 outlines procedures for upgrading system software components.
- Appendix A, “[Specifications](#)” on page 33 lists the BlendPRO-II’s specifications.
- Appendix B, “[Contact Information](#)” on page 41 lists important Barco contact, RMA, warranty and technical support details.

---

## How to Use This Guide

Following are important tips for streamlining your use of this User's Guide in its electronic "PDF" form.

### Navigating

Use Acrobat Reader's "bookmarks" to navigate to the desired location. All chapter files have the same bookmark structure for instant navigation to any section. Please note:



- Extensive hyperlinks are provided within the chapters.
- Use Acrobat's "**Go to Previous View**" and "**Return to Next View**" buttons to trace your complete navigational path.
- Use the "**Previous Page**" and "**Next Page**" buttons to go to the previous or next page within a file.
- Use Acrobat's extensive search capabilities, such as the "**Find**" tool and "**Search Index**" tool to perform comprehensive searches as required.

### Table of Contents and Index

Use the **Table of Contents** bookmarks to navigate a desired topic. Click any item to instantly jump to that section of the guide. You can also use the **Index** to jump to specific topics within a chapter. Each page number in the **Index** is a hyperlink.

### General Operations

To ensure trouble-free operation, please follow all procedures in the **Installation** and **Operation** sections of this manual.

- Refer to Chapter 3, "[Installation](#)" on page 21 and Chapter 4, "[Operation](#)" on page 29 for details.
- Should you have any questions regarding the installation or operation of the BlendPRO-II system, please consult with the factory. Refer to Appendix B, "[Contact Information](#)" on page 41 for information.

---

## Conventions

The following conventions are used throughout this guide:

- The symbol ■ denotes an operations procedure.
- The symbol ▲ denotes an example.
- Entries written in bold-face capital letters denote physical buttons or chassis connectors.

▲ Use the **GENLOCK** connector to ...

# 1. Introduction

About the BlendPRO-II

---

## About the BlendPRO-II

The BlendPRO-II is a “presentation” system component that allows standard high-resolution images (as generated by multiple ScreenPro-II units) to be displayed in a multi-projector widescreen format. The system completely eliminates the need to “pre-overlap” source material during the content creation phase of your presentation.

BlendPRO-II receives signals from up to four ScreenPro-II units (via high-resolution DVI connections) and processes the video for display in multi-projector widescreen format. Processing includes:

- Data doubling to generate overlapped projected regions.
- Edge-feathering of the overlapped images.

The amount of data overlap and edge-feathering parameters are user-programmable. BlendPRO-II supports simultaneous digital and analog output signals to separate DVI and HD-15 connectors. Refer to the [“Connectivity Diagram”](#) section on page 14 for an illustration of a typical BlendPRO-II application.

In order to synchronize the ScreenPRO-II units for use in a widescreen projection application (in conjunction with the ScreenPRO-II Controller), BlendPRO-II provides a **Widescreen Lock** output which is used to lock each ScreenPRO-II unit to one common master timing signal. In addition, this signal supports real-time command synchronization between all connected ScreenPRO-II units, which in turn guarantees that all time-critical functions (such as T-Bar commands) occur synchronously across all units.

Please note the following important points:

- For applications where it is desirable to frame lock the system’s widescreen output to a master house sync (such as an NTSC or PAL black burst signal), a Genlock input BNC is provided.
- The unit frame locks to CSYNC (composite bi- or tri-level) sync signals.
- BlendPRO-II supports only progressive video formats.
- The unit does not provide scaling or frame rate conversion of input sources.
- Output timing matches input timing.
- Video delay through the BlendPRO-II is 6 video lines or less.
- DVI outputs from ScreenPRO-II must be H & V locked, using the **“Widescreen Lock”** output from BlendPRO-II.

---

## Features

The BlendPRO-II system includes the following advanced features:

- Blending of up to four ScreenPro-II units.
- User programmable data doubling, edge-feathering, and output gamma.
- Simultaneous digital and analog outputs.
- Real-time command synchronization between all connected ScreenPRO-II units.
- Separate Genlock and Widescreen Lock connections (BNC).
- Progressive video format support.
- Low video delay, less than 6 lines.
- Integral test pattern generator.

**Important**

All system setup and control is performed via Ethernet, through the ScreenPRO-II Controller.

---

## Application Questions

At Barco, we take pride in offering unique solutions to demanding technical problems. If you have application questions, require further information or would like to discuss your application requirements in more detail, please call (916) 859-2500. Our Customer Support Engineers will be happy to supply you with the support you need. Refer to Appendix B, "[Contact Information](#)" on page 41 for details.

## Connectivity Diagram

The figure below illustrates a sample connectivity diagram:

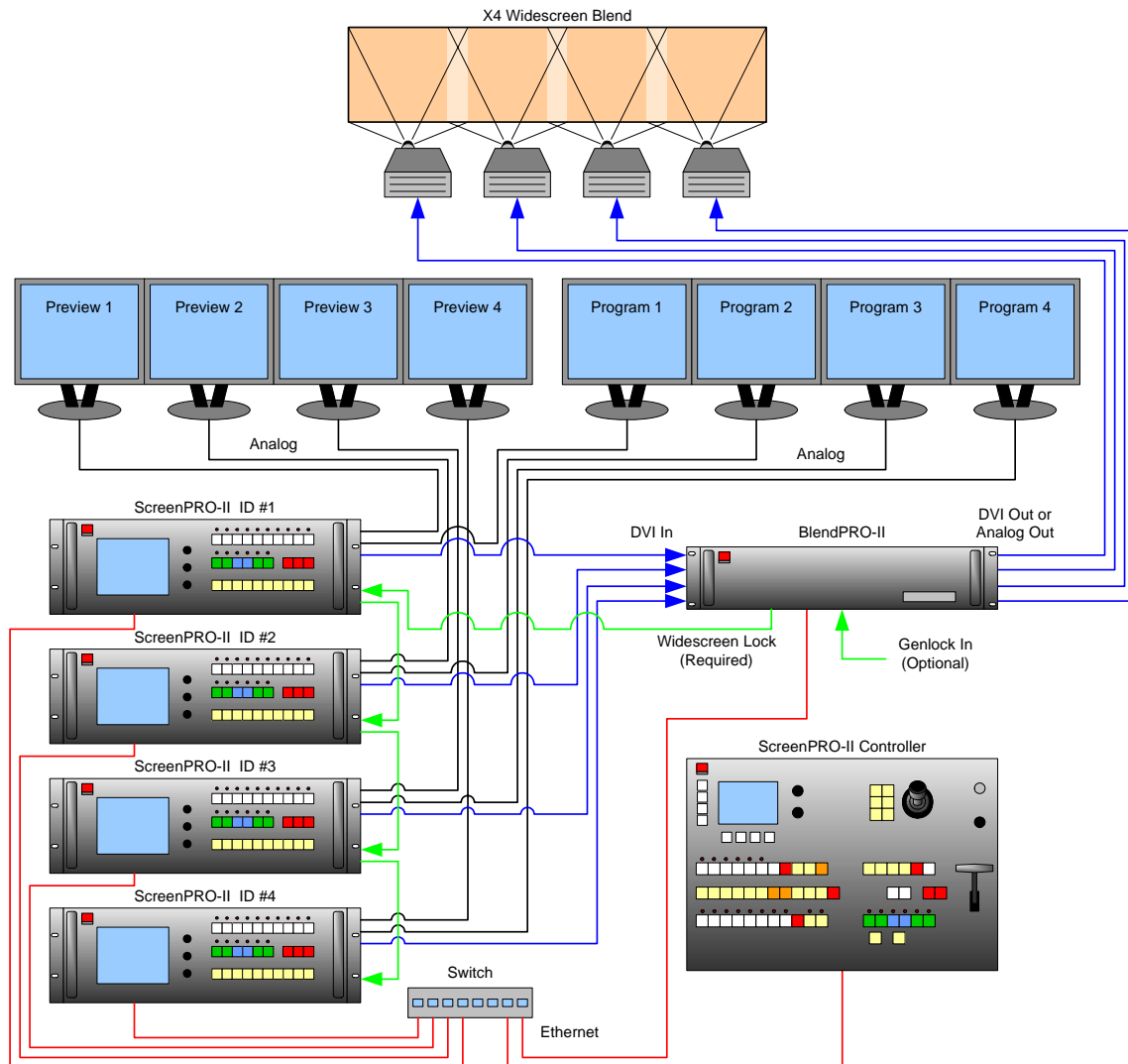

Figure 1-1. Typical BlendPRO-II Application (sample)

Please note the following points regarding the system:

- The maximum system configuration of four ScreenPRO-II units is shown.
- Ethernet connects the BlendPRO-II to all ScreenPRO-II units and the ScreenPRO-II Controller, via a network switch.
- DVI signals connect the ScreenPRO-II outputs to BlendPRO-II, and the BlendPRO-II to each projector input.
- Analog connectivity from each ScreenPRO-II is used for monitoring.
- The **Widescreen Lock** output from BlendPRO-II is used to lock each ScreenPRO-II system. These connections are required.

## 2. Hardware Orientation

---

### In This Chapter

This chapter provides detailed diagrams of the system's front and rear panels. The following topics are discussed:

- [BlendPRO-II Front Panel](#)
- [BlendPRO-II Rear Panel](#)

## 2. Hardware Orientation

### BlendPRO-II Front Panel

---

## BlendPRO-II Front Panel

The figure below illustrates the BlendPRO-II front panel:



**Figure 2-1.** BlendPRO-II Front Panel

There are no user controls on the front panel of the BlendPRO-II chassis. All operating procedures are performed through the ScreenPRO-II Controller. Refer to Chapter 4, "[Operation](#)" on page 29 for additional details.



# BlendPRO-II Rear Panel

The figure below illustrates the BlendPRO-II rear panel:

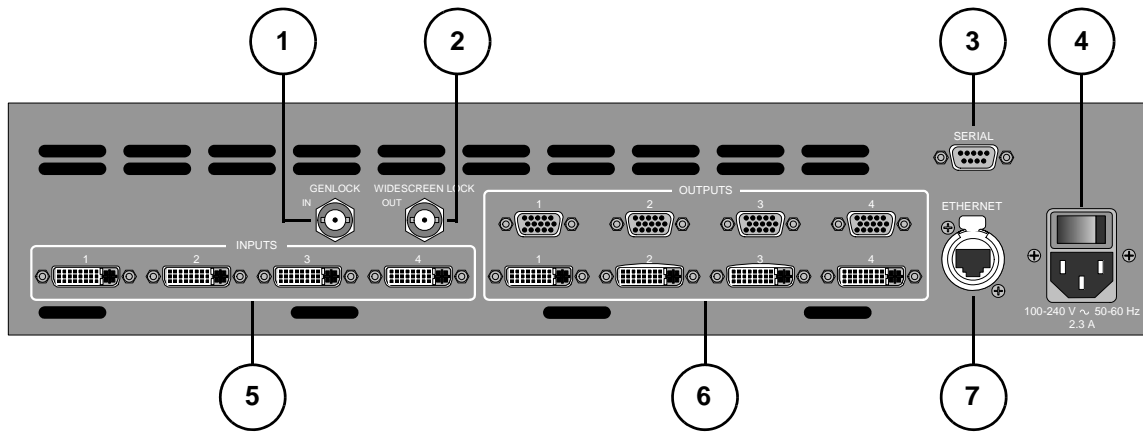

Figure 2-1. BlendPRO-II Rear Panel

1) <a href="#">Genlock In</a>	5) <a href="#">Inputs Section</a>
2) <a href="#">Widescreen Lock Out</a>	6) <a href="#">Outputs Section</a>
3) <a href="#">Serial Port</a>	7) <a href="#">Ethernet Port</a>
4) <a href="#">AC Connector</a>	

Following are descriptions of each rear panel connector and section:

### 1) Genlock In

One BNC connector is provided for a **Genlock Input**, which can be used to lock BlendPRO-II and its associated ScreenPro-II inputs to an external source if desired. Please note:

- ~ BlendPRO-II can genlock to Composite bi or tri-level syncs.
- ~ Similarly, black burst type syncs can be used within the limitations of the BlendPRO-II input resolutions.
- ~ Because BlendPRO-II does not contain a loop-through connector, the incoming sync will be terminated to 75 Ohms.

### 2) Widescreen Lock Out

One BNC connector is provided for a **Widescreen Lock Output**, which is required to supply H and V sync locking information to each ScreenPro-II **GENLOCK** input, as well as communicate various widescreen synchronization commands via a proprietary interface.

#### Important

This connector is not a loop-through, and can only be used with BlendPRO-II and ScreenPRO-II systems.

## 2. Hardware Orientation

### BlendPRO-II Rear Panel

#### 3) Serial Port

One 9-pin D connector is provided for RS-232 serial communications with BlendPRO-II, typically for diagnostic purposes. The port is configured as a DCE, 115K Baud, 8 data bit, 1 stop bit, and no parity bits. The port can be connected to a standard PC serial port with a straight through DB-9 to DB-9 cable.

In Appendix A, refer to the “[Serial Connector](#)” section on page 40 for pinouts.

#### 4) AC Connector

One **AC Connector** is provided for connecting BlendPRO-II to your facility’s AC power source. The integral switch turns the chassis on and off.

#### 5) Inputs Section

The figure below illustrates the **Inputs Section**:

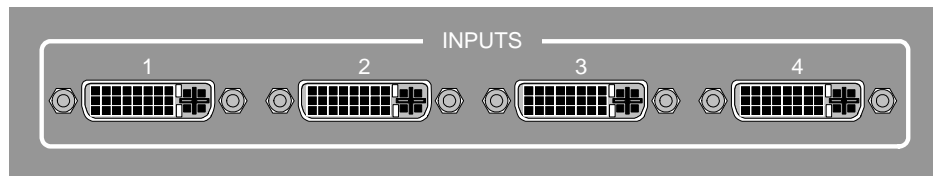

**Figure 2-2.** BlendPRO-II Inputs Section

The **Inputs Section** includes four DVI digital inputs per DDWG 1.0 specifications. All four are DVI-D (digital, single link, receptacle) using DVI-I connectors to allow flexible cabling choices. Please note:

- ~ Each input accepts DVI progressive RGB signals with a pixel clock speed from 25 - 162MHz (1600x1200x60Hz).
- ~ Each input must be of the same resolution and H/V locked together.

In Appendix A, refer to the “[DVI Connector Pinouts](#)” section on page 38 for pinout details.

## 2. Hardware Orientation

BlendPRO-II Rear Panel

### 6) Outputs Section

The figure below illustrates the **Outputs Section**:

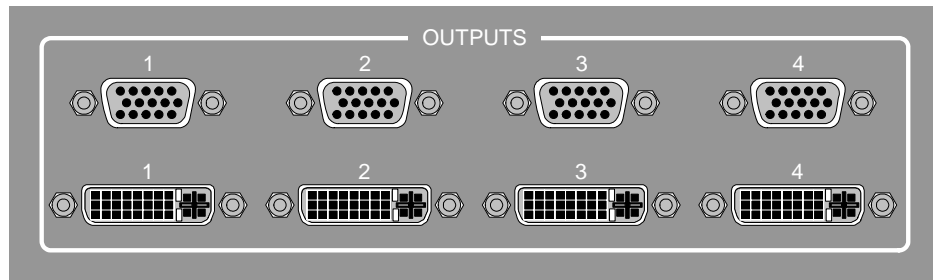

Figure 2-3. BlendPRO-II Outputs Section

The **Outputs Section** includes four digital and four analog outputs:

- ~ **DVI** — the four DVI digital outputs are per DDWG 1.0 specifications. All four are DVI-D (digital, single link, receptacle) using DVI-I connectors. The DVI outputs are of the same resolution as the inputs.

In Appendix A, refer to the “[DVI Connector Pinouts](#)” section on page 38 for pinout details.

- ~ **Analog** — the four HD-15 analog outputs provide progressive RGB. Analog syncs can be configured for 5 wire (RGBHV), 4 wire (RGB composite sync) or 3 wire (sync on green) operation. Please note:
  - Video components are driven at 700mV peak amplitude (1V for SOG) at 75 Ohm terminations.
  - Sync components (4 and 5 wire) are driven at TTL compatible levels at 75 Ohm terminations.
  - The analog outputs is driven at the same resolution and in sync with the DVI outputs.
  - Data is identical to the data on the DVI outputs, except that the analog circuits are 10-bit, and thus preserve the 10-bit result of the data doubling and feathering operations.

In Appendix A, refer to the “[Analog 15-pin D Connector](#)” section on page 37 for pinout details.

### 7) Ethernet Port

One RJ-45 (Neutrik) connector is provided for **Ethernet** communications with BlendPRO-II. Ethernet is the primary means of controlling the BlendPRO-II. Please note:

- ~ The Ethernet port is 10/100 Mbit auto-sensing capable.
- ~ The port is primarily configured to run as a DHCP client, although static IP can be used if desired.

In Appendix A, refer to the “[Ethernet Connector](#)” section on page 39 for pinouts.

## 2. Hardware Orientation

BlendPRO-II Rear Panel

## 3. Installation

---

### In This Chapter

This chapter provides detailed instructions for installing the BlendPRO-II hardware. The following topics are discussed:

- [Safety Precautions](#)
- [Unpacking and Inspection](#)
- [Site Preparation](#)
- [Cable and Adapter Information](#)
- [Rack-Mount Installation](#)
- [Power Installation](#)
- [Signal Installation](#)
- [Format Connection Table](#)

### 3. Installation

#### Safety Precautions

---

## Safety Precautions

For all BlendPRO-II installation procedures, observe the following important safety and handling rules to avoid damage to yourself and the equipment:

- To protect users from electric shock, ensure that the power supplies for each unit connect to earth via the ground wire provided in the AC power Cord.
  - The AC Socket-outlet should be installed near the equipment and be easily accessible.
- 

## Unpacking and Inspection

Before opening the BlendPRO-II box, inspect it for damage. If you find any damage, notify the shipping carrier immediately for all claims adjustments. As you open the box, compare its contents against the packing slip. If you find any shortages, contact your Barco sales representative.

Once you have removed all the components from their packaging and checked that all the listed components are present, visually inspect each unit to ensure there was no damage during shipping. If there is damage, notify the shipping carrier immediately for all claims adjustments.

---

## Site Preparation

The environment in which you install your BlendPRO-II(s) should be clean, properly lit, free from static, and have adequate power, ventilation, and space for all components.

---

## Cable and Adapter Information

The table below provides information regarding supplied cables and adapters:

**Table 3-1.** BlendPRO-II System Cables and Adapters

Cable / Adapter	Description	Quantity
AC Power Cord	7 foot, 10A	1

---

## Rack-Mount Installation

BlendPRO-II units are designed to be rack mounted and are supplied with front rack-mount hardware. Please note the following important points:

- Rear rack-mount brackets are available as a kit, and are recommended for use when units are mounted in transit cases.
- When rack mounting the unit, remember that the maximum ambient operating temperature for the unit is 40 degrees C.
- Leave sufficient front and rear space to make sure that the airflow through the fan and vent holes is not restricted.
- When installing equipment into a rack, distribute the units evenly to prevent hazardous conditions that may be created by uneven weight distribution.
- Connect the unit only to a properly rated supply circuit.
- Reliable grounding (earthing) of rack-mounted equipment should be maintained.
- Rack mount the unit from the front rack ears using four rack screws (not supplied). Rack threads may be metric or otherwise — depending upon the rack type.
- Install the *lower* of the two mounting holes first.

---

## Power Installation

- Use the following steps to install power to the BlendPRO-II:
  1. Connect an AC power cord to the AC Power Connector on the rear of the BlendPRO-II, and then to an AC outlet.
  2. Connect AC Power cords (or AC adapters) to all peripheral equipment, such as ScreenPRO-II systems, monitors and projectors. Please note:
    - ~ Connect each unit only to a properly rated supply circuit.
    - ~ Reliable grounding of rack-mounted equipment should be maintained.

### 3. Installation

#### Power Installation

## Power Cord/Line Voltage Selection

BlendPRO-II is rated to operate with the following supplies:

- Input Power: 100-240 VAC, 47-63 Hz
- Power Consumption: 80 watts maximum

BlendPRO-II performs line voltage selection automatically, and no user controls are required. The AC power cords must be accessible so that they can be removed during field servicing.



#### Warning

When the BlendPRO-II is used in the 230-volt mode, a UL listed line cord rated for 250 volts at 15 amps must be used and must conform to IEC-227 and IEC-245 standards. This cord will be fitted with a tandem prong-type plug.

The rear panel ON/OFF switch does not disconnect the unit from input AC power. To facilitate disconnection of AC power, the power cord must be connected to an accessible outlet near the unit.

Building Branch Circuit Protection: For 115 V use 20 A, for 230 V use 8 A.



Figure 3-1. Tandem Prong-type Plug

#### Avertissement

La choix de la ligne de voltage se réalise automatiquement par le BlendPRO-II Transformateur Graphique. On n'a pas besoin du controller usager pour la choix de la ligne de voltage.

#### Warnung

Das BlendPRO-II gerät mu beim Anschlu an 240V ~ mit einer vom VDE auf 250V/10A geprüften Netzleitung mit einem Schukostecker ausgestattet sein.



## Signal Installation

The figure below illustrates a sample BlendPRO-II system, which uses the maximum four ScreenPRO-II units. Use this figure for reference during the signal installation process. If required, refer to the “[BlendPRO-II Rear Panel](#)” section on page 17 in Chapter 2 for details on all rear panel connectors.

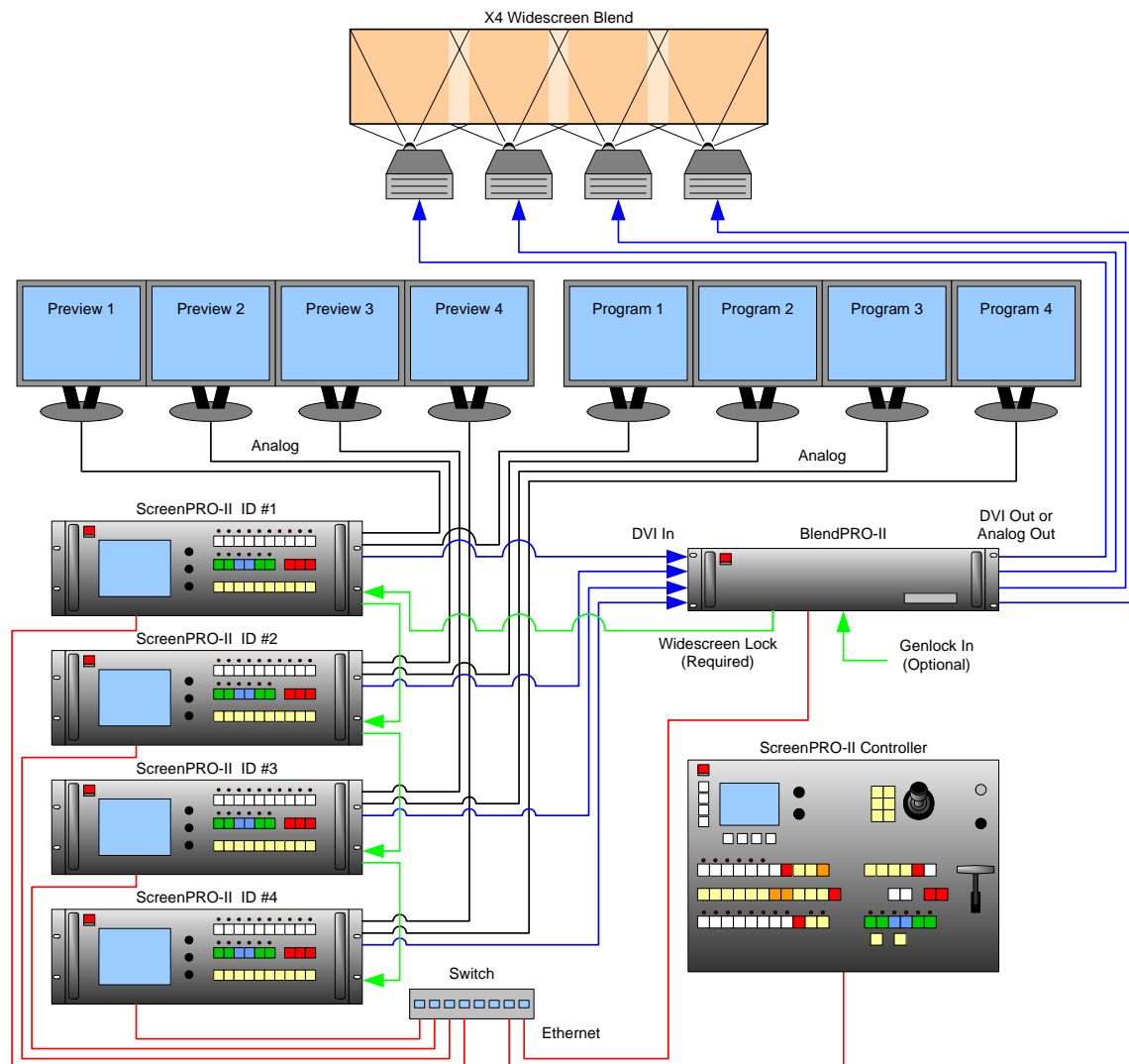

**Figure 3-2.** BlendPRO-II System Diagram (sample)

- Use the following steps to install signals to/from the BlendPRO-II:
  1. Connect your Program/Preview monitoring as required, using the analog outputs from your selected ScreenPRO-II units. The units' DVI outputs must be reserved for connection to BlendPRO-II.
  2. Connect Ethernet communications to all ScreenPRO-II units, to the BlendPRO-II, and to the ScreenPRO-II Controller. A totally "local" network is recommended,

### 3. Installation

#### Signal Installation

without IP connections to the outside world. Use standard Ethernet cables in conjunction with an Ethernet switch.

3. Connect a DVI output from each ScreenPRO-II unit (up to the maximum of 4) to the DVI inputs on BlendPRO-II.
4. Connect the DVI or analog outputs from BlendPRO-II to the inputs of your selected projectors (up to the maximum of 4). If you are using the analog outputs, refer to the [“Format Connection Table”](#) section on page 28 for connection details using a customer supplied breakout cable.
5. External **Genlock** connections to BlendPRO-II are optional.
  - a. If desired (particularly if you will be using synchronous cameras), use a BNC cable to connect a PAL or NTSC black burst (or a composite sync) signal to the **GENLOCK IN** connector on BlendPRO-II.
  - b. *Do not* connect an external Genlock signal to any ScreenPRO-II unit in your system.
6. **Widescreen Lock** connections are *mandatory*. Use the figure below for reference:

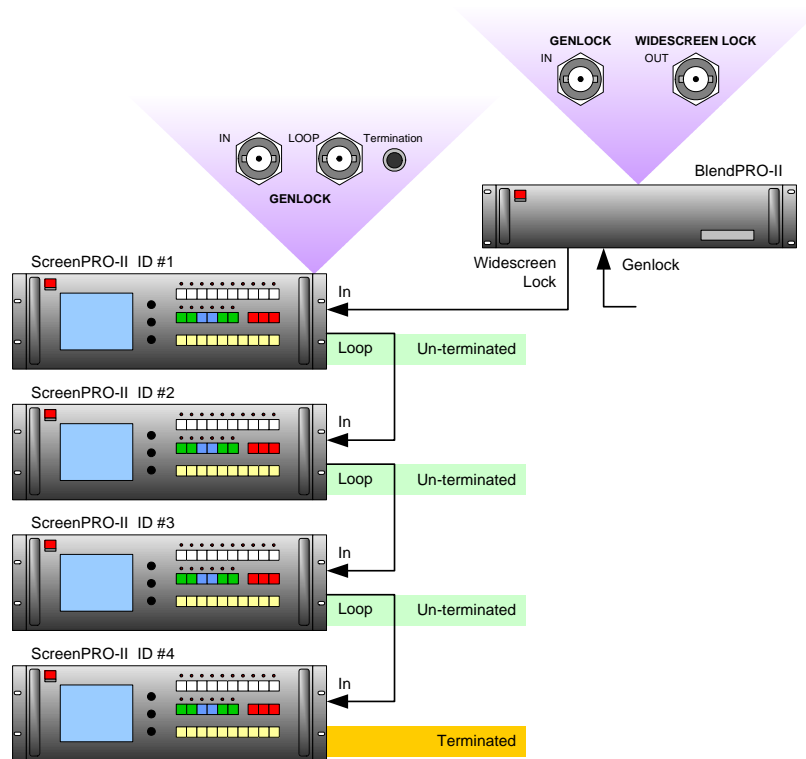

Figure 3-3. BlendPRO-II Widescreen Lock Connections (sample)

- a. Connect a BNC cable from BlendPRO-II's **WIDESCREEN LOCK** output to the **GENLOCK IN** connector on the ScreenPRO-II unit with the **lowest numbered ID**.
- b. Connect the first ScreenPRO-II's **GENLOCK LOOP** connector to the **GENLOCK IN** connector on the ScreenPRO-II unit with the **next highest numbered ID**.

### 3. Installation

#### Signal Installation

- c. (If your system includes three ScreenPRO-IIs) — Connect the second ScreenPRO-II's **GENLOCK LOOP** connector to the **GENLOCK IN** connector on the ScreenPRO-II with the **next highest numbered ID**.
- d. (If your system includes four ScreenPRO-IIs) — Connect the third ScreenPRO-II's **GENLOCK LOOP** connector to the **GENLOCK IN** connector on the ScreenPRO-II unit with the **highest numbered ID**.
- e. Set the **Termination Switch** for all ScreenPRO-IIs in your system:
  - For all ScreenPRO-IIs **except the last one** in the chain, ensure that the ScreenPRO-II is un-terminated (**HI-Z**). Refer to the [“ScreenPRO-II Genlock Termination”](#) section on page 27 for details.
  - On the **last unit** in the chain (only), ensure that the ScreenPRO-II is terminated (**75-OHM**).

Please continue with system setup, menu orientation and operations, as outlined in Chapter 4, [“Operation”](#) on page 29.

## ScreenPRO-II Genlock Termination

On the rear of each ScreenPRO-II chassis, one recessed **Termination Switch** is provided for genlock termination (adjacent to the **Genlock Loop** connector).

- **Terminated** — when the switch is pushed in, the connection is terminated (75 Ohms).
- **Un-terminated** — when the switch is out, the connection is un-terminated.

If a particular ScreenPRO-II chassis is the last device in a reference video chain, ensure that the **Termination Switch** is pushed in. If a particular ScreenPRO-II chassis is in the middle of a reference chain, ensure that the **Termination Switch** is out.

### 3. Installation

#### Format Connection Table

---

## Format Connection Table

Use the following table to connect BlendPRO-II's analog RGB output to various analog projector inputs (3 wire, 4 wire and 5 wire). Using a customer supplied VGA to 5 x BNC breakout cable, multiple combinations are possible. Cells with checks denote the connections required for the indicated format.

**Note**

For RGB with H and V sync, use the VGA connector directly.

**Table 3-2.** Analog Output Combinations using Breakout Cable

Breakout Cable Wire Color	RGB Sync on Green	RGB Comp Sync	RGB Separate H V
R	✓	✓	✓
G	✓	✓	✓
B	✓	✓	✓
H Sync		✓	✓
V Sync			✓

Please contact **Barco Technical Support** for information on obtaining breakout cables. In Appendix B, refer to the "[Contact Information](#)" section on page 42 for details.

## 4. Operation

---

### In This Chapter

This chapter provides detailed operating instructions for the BlendPRO-II. The following topics are discussed:

- [Control Overview](#)

## 4. Operation

### Control Overview

---

## Control Overview

All BlendPRO-II setup and operating procedures are performed through the **ScreenPRO-II Controller**. There are no user controls on the BlendPRO-II unit itself.

**Important**

Refer to the “**ScreenPRO-II Controller User’s Guide**” for complete setup and operating procedures.

# 5. Upgrading Software

---

## In This Chapter

This chapter provides instructions for upgrading BlendPRO-II system software. The following topics are discussed:

- [Software Upgrade Overview](#)

## 5. Upgrading Software

### Software Upgrade Overview

---

## Software Upgrade Overview

All software upgrade procedures are performed through the ScreenPRO-II Controller. There are no user controls provided on the BlendPRO-II unit itself.

Please note:

- **Code compatibility** — when the ScreenPRO-II Controller connects to the individual ScreenPRO-II units and to BlendPRO-II, it automatically checks the compatibility of the code versions.

If the ScreenPRO-II Controller's code version matches that of the ScreenPRO-II units and BlendPRO-II, the Controller's **System Status Menu** is shown — and you will not need to download code.

- ~ If the message "**Checksum Mismatch**" appears on the **System Status Menu**, you must download code.
- ~ If the ScreenPRO-II Controller's code version is *incompatible* with the either the ScreenPRO-II units' code version or the BlendPRO-II's code version (or a combination of units), all buttons will flash on the Controller console. The **System Status Menu** is shown with the message "**Please Upgrade.**"

#### Important

Refer to the "**ScreenPRO-II Controller User's Guide**" for complete software upgrade procedures.



# A. Specifications

---

## In This Appendix

This appendix provides detailed technical specifications for the BlendPRO-II. The following topics are discussed:

- [Input Specifications](#)
- [Output Specifications](#)
- [User Control Specifications](#)
- [Physical and Electrical Specifications](#)
- [Communications Specifications](#)
- [Agency Specifications](#)
- [Pinouts](#)

## A. Specifications

### Input Specifications

---

## Input Specifications

The table below lists BlendPRO-II input specifications.

**Table A-1.** BlendPRO-II Input Specifications

Parameter	Detail	Specification
DVI Inputs 1 - 4	Connector	(4) DVI-D connectors (digital, single link, receptacle), each input per DDWG 1.0 specifications.
	Video	Progressive RGB
	Clock Speed / Resolution	25 - 162MHz (1600x1200x60Hz)
	Lock	All inputs must be of the same resolution and H/V locked.
Genlock Input	Connector	BNC
	Signal	Connects to master house sync, e.g., NTSC or PAL black burst. Also genlocks to CSYNC (composite bi- or tri-level) sync signals.

---

## Output Specifications

The table below lists BlendPRO-II output specifications.

**Table A-2.** BlendPRO-II Output Specifications

Parameter	Detail	Specification
DVI Outputs 1 - 4	Connector	(4) DVI-D connectors (digital, single link, receptacle), each input per DDWG 1.0 specifications.
	Video	Progressive RGB
	Clock Speed / Resolution	25 - 162MHz (1600x1200x60Hz)
Analog Outputs 1 - 4	Connector	(4) HD-15 connectors
	Video	Progressive RGB
	Sync	5 wire (RGBHV), 4 wire (RGB composite sync) or 3 wire (sync on green)
	Clock Speed / Resolution	25 - 162MHz (1600x1200x60Hz)
Widescreen Lock	Connector	BNC
	Signal	Proprietary, supplies H and V sync locking information to each ScreenPro-II Genlock input

## User Control Specifications

The table below lists BlendPRO-II user control specifications.

**Table A-3.** BlendPRO-II User Control Specifications

Parameter	Detail	Specification
User Control	Operations	No local controls provided.
	Setup	All setup functions performed from ScreenPRO-II Controller.
	Remote control	All control functions performed from ScreenPRO-II Controller.

## Physical and Electrical Specifications

The table below lists BlendPRO-II physical and electrical specifications.

**Table A-4.** BlendPRO-II Physical and Electrical Specifications

Parameter	Detail	Specification
Power	Connector	Standard IEC, integral on/off switch
	Input Power	47-63 Hz, 100-240 VAC
	Power Consumption	80 watts maximum
Mechanical	Chassis	<b>H:</b> 3.50 inches (8.89 cm)
		<b>W:</b> 17.00 inches (43.18 cm)
		<b>W:</b> 19.00 inches (48.26 cm) with rackmount wings
		<b>D:</b> 15.00 inches (38.10 cm)
Temperature		0-40 degrees C
Humidity		0-95% non-condensing
Mounting		2 RU rack mount (19 inch, using front and rear mounts)
Weight		17.0 lbs (7.71 kg)
Shipping Weight		22 lbs (9.97 kg)

## A. Specifications

### Communications Specifications

---

## Communications Specifications

The table below lists BlendPRO-II communications specifications.

**Table A-5.** BlendPRO-II Communications Specifications

Parameter	Detail	Specification
Communications	RS-232	DB-9 Female, DCE, 115k Baud
	Ethernet	RJ-45, 10/100 Mbps Autosense

---

## Agency Specifications

The table below lists BlendPRO-II agency specifications.

**Table A-6.** BlendPRO-II Agency Specifications

Parameter	Detail	Specification
Agency Specifications	EMI/EMC	EN55103-1 E4, EN55103-2, FCC Part 15 Subpart B Class A
	Safety	EN 60950 Class 1

## Pinouts

The following topics are discussed in this section:

- [Analog 15-pin D Connector](#)
- [DVI Connector Pinouts](#)
- [Ethernet Connector](#)
- [Serial Connector](#)

### Analog 15-pin D Connector

The figure below illustrates the analog 15-pin D connector:

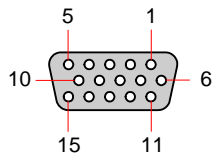

**Figure A-1.** Analog 15-pin D Connector, chassis view

The table below lists Analog 15-pin D connector pinouts.

**Table A-7.** Analog 15-pin D Connector Pinouts

Pin	Signal	Pin	Signal
1	Red	9	
2	Green	10	GND
3	Blue	11	
4		12	
5		13	H Sync or C Sync
6	Red return	14	V Sync
7	Green return	15	
8	Blue return		

## A. Specifications

### Pinouts

## DVI Connector Pinouts

The figure below illustrates the DVI-I connector:

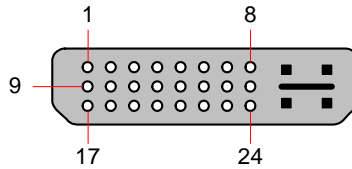

**Figure A-2.** DVI-I Connector

The table below lists DVI-I Connector pinouts. Please note:

- T.M.D.S = Transition Minimized Differential Signal
- DDC = Display Data Channel

**Table A-8.** DVI-I Connector Pinouts

Pin	Signal	Pin	Signal
1	T.M.D.S. Data 2-	13	T.M.D.S. Data 3+
2	T.M.D.S. Data 2+	14	+5V Power
3	T.M.D.S. Data 2/4 Shield	15	ground (for +5V)
4	T.M.D.S. Data 4-	16	Hot Plug Detect
5	T.M.D.S. Data 4+	17	T.M.D.S. Data 0-
6	DDC Clock	18	T.M.D.S. Data 0+
7	DDC Data	19	T.M.D.S. Data 0/5 Shield
8		20	T.M.D.S. Data 5-
9	T.M.D.S. Data 1-	21	T.M.D.S. Data 5+
10	T.M.D.S. Data 1+	22	T.M.D.S. Clock Shield
11	T.M.D.S. Data 1/3 Shield	23	T.M.D.S. Clock +
12	T.M.D.S. Data 3-	24	T.M.D.S. Clock -

## Ethernet Connector

The figure below illustrates the Ethernet connector:

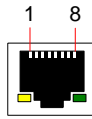

**Figure A-3.** Ethernet Connector

The table below lists Ethernet connector pinouts.

**Table A-9.** Ethernet Connector Pinouts

Pin	Signal	Wire Color
1	TX Data +	White / Orange
2	TX Data -	Orange
3	RX Data +	White / Green
4		Blue
5		White / Blue
6	RX Data -	Green
7		White / Brown
8		Brown

## A. Specifications

### Pinouts

## Serial Connector

The figure below illustrates the Serial connector:

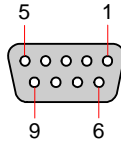

**Figure A-4.** Serial Connector

The table below lists Serial connector pinouts.

**Table A-10.** Serial Connector Pinouts

Pin	RS-232 Signal	Description
1	CD	Carrier Detect
2	RXD	Received Data
3	TXD	Transmitted Data
4	DTR	Data Terminal Ready
5	GND	Signal Ground
6	DSR	Data Set Ready
7	RTS	Request To Send
8	CTS	Clear To Send
9	RI	Unused



## B. Contact Information

---

### In This Appendix

The following topics are discussed in this Appendix:

- [Warranty](#)
  - [Return Material Authorization \(RMA\)](#)
  - [Contact Information](#)
- 

### Warranty

All video products are designed and tested to the highest quality standards and are backed by a full 3-year parts and labor warranty. Warranties are effective upon delivery date to customer and are non-transferable. Barco warranties are only valid to the original purchaser/owner. Warranty related repairs include parts and labor, but do not include faults resulting from user negligence, special modifications, lightning strikes, abuse (drop/crush), and/or other unusual damages.

The customer shall pay shipping charges when unit is returned for repair. Barco will cover shipping charges for return shipments to customers.

---

### Return Material Authorization (RMA)

In the unlikely event that a product is required to return for repair, please call the following number and ask for a Sales Engineer to receive a Return Merchandise Authorization number (RMA).

- (888) 414-7226

RMA Conditions are listed below:

- a. Prior to returning any item, you must receive a Return Merchandise Authorization (RMA) number.
- b. All RMA numbers must appear on their return-shipping label.
- c. RMA numbers are valid for ten (10) days from issue date.
- d. All shipping and insurance charges on all RMAs must be prepaid by the customer

## B. Contact Information

Contact Information

---

### Contact Information

#### **Barco Media and Entertainment**

11101 Trade Center Drive  
Rancho Cordova, California 95670  
USA

- Phone: (916) 859-2500
- Fax: (916) 859-2515
- Websites:
  - ~ [www.folsom.com](http://www.folsom.com)
  - ~ [www.events.barco.com](http://www.events.barco.com)

#### **Sales Contact Information**

- Direct: (916) 859-2505
- Toll Free: (888) 414-7226
- E-mail: [folsomsales@barco.com](mailto:folsomsales@barco.com)

#### **Barco N.V.**

Noordlaan 5  
8520 Kuurne  
BELGIUM

- Phone: +32 56.36.82.11
- Fax: +32 56.35.16.51
- Website: [www.barco.com](http://www.barco.com)

#### **Technical Support Information**

- Tech Line: (866) 374-7878 — 24 hours per day, 7 days per week
- E-mail: [folsomsupport@barco.com](mailto:folsomsupport@barco.com)

# Index

## A

About BlendPRO-II .....	12
AC	
connector .....	18
power cords .....	24
Acrobat usage .....	11
navigating and searching .....	11
Adapter information .....	22
Address, company .....	3
Agency specifications .....	36
Analog 15-pin D connector pinouts .....	37
Application questions .....	13

## B

Barco	
company address .....	3
events, contact information .....	42
sales contact information .....	42
technical support information .....	42
warranty .....	41
BlendPRO-II	
about .....	12
control overview .....	30
features .....	13
front panel connectors .....	16
hardware installation .....	21
hardware orientation .....	15
introduction to .....	9
operation .....	29
rear panel connectors .....	17
specifications .....	33
system diagram .....	25
upgrading software .....	31

## C

Cable information .....	22
Change history .....	6
Chapter structure .....	10
Communications specifications .....	36
Company address .....	3
Connectivity, system diagram .....	14
Connector	
AC .....	18
analog 15-pin D pinouts .....	37
DVI pinouts .....	38
Ethernet .....	19
Ethernet pinouts .....	39
RS-232 .....	18
serial pinouts .....	40
Connectors	
front panel .....	16
rear panel .....	17
Contact information .....	42
Control overview .....	30
Conventions .....	11
Copyright .....	2

## D

Diagram	
system .....	25
system connectivity .....	14
Documentation conventions and symbols .....	11
DVI connector pinouts .....	38

## E

Electrical specifications .....	35
Equipment marking terms .....	5
Ethernet	
connector .....	19
connector pinouts .....	39
port .....	19

# Index

## F

FCC statement	2
Features, BlendPRO-II	13
Front panel connectors	16

## G

Genlock termination	27
Guarantee and compensation	2

## H

Hardware	
installation	21
orientation	15
History, change	6
How to	
install BlendPRO-II power	23
install signals to/from BlendPRO-II	25
use this guide	11
Hyperlinks	11

## I

Information, cables and adapters	22
Input specifications	34
Inputs section	18
Inspection	22
Installation	
hardware	21
power	23
rack mount	23
safety precautions	22
signals	25
site preparation	22
unpacking and inspection	22

Introduction to BlendPRO-II	9
-----------------------------	---

## L

Line voltage selection	24
------------------------	----

## N

Notice	2
--------	---

## O

Operation, BlendPRO-II	29
Operators safety summary	4
Orientation, hardware	15
Output specifications	34
Overview, control	30

## P

PDF file usage	11
navigating and searching	11
Physical specifications	35
Pinouts	37
analog 15-pin D connector	37
DVI connector	38
Ethernet connector	39
serial connector	40
Power	
cord, line voltage selection	24
installation	23
precautions	24

## R

Rack mount installation	23
Rear panel connectors	17
Return material authorization	41
RMA	41
RS-232 port	18

## S

Safety	
precautions	22
summary	4

## Index

Sales contact information .....	42
Serial	
connector pinouts .....	40
port .....	18
Signal installation .....	25
Site preparation .....	22
Software	
upgrade overview .....	32
upgrading .....	31
Specifications .....	33
agency .....	36
communications .....	36
electrical .....	35
input .....	34
output .....	34
physical .....	35
pinouts .....	37
user control .....	35
Support, technical information .....	42
Symbols .....	11
System diagram .....	25

## T

Technical support information .....	42
Termination	
genlock .....	27
switch .....	27
Terms, equipment marking .....	5
Trademarks .....	3

## U

Unpacking .....	22
Upgrading software .....	31
User control specifications .....	35

## W

Warranty .....	41
----------------	----

# Index